

EXAMPLE FLOW RATES

Here are the flow rates using the lowest and highest pump sizes

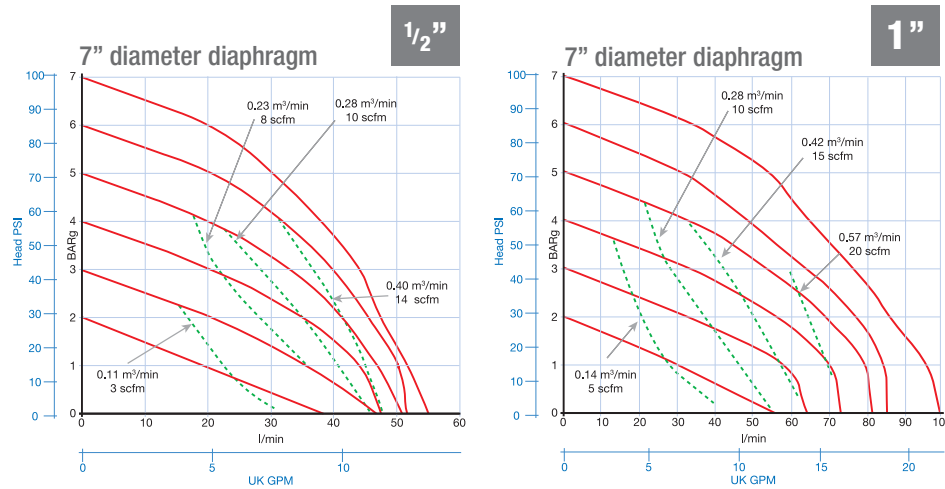

For flow rates of other pump sizes, please contact us by telephone or visit our website. The flow rates can also be seen in our company brochure.

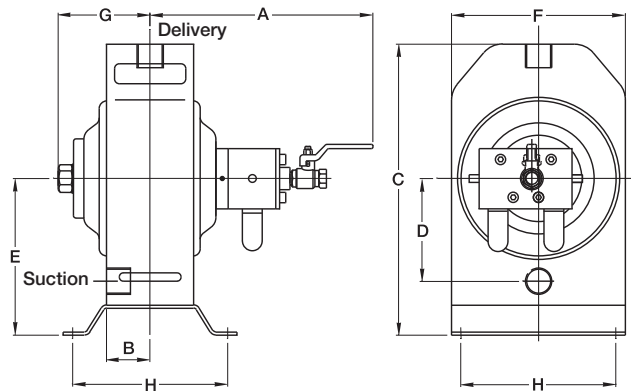

Minichem Virgin & Anti Static PTFE									Diaphragm Diameter	
Size	A	B	C	D	E	F	G	H	Diaphragm Diameter	
1/2" - 1"	282	55	368	130	198	220	116	196	23	7"

Maximum operating pressure 7.2 bar (105 PSIG) Dimensions in mm

Specifications subject to change without notice.

The One-Nut Double Diaphragm Pump, unique to Flotronic, takes pump performance far beyond traditional style Double Diaphragm pumps. This fast maintenance concept literally turns the conventional pump inside out. Fluid passes between the diaphragms directly through the centre of the pump with air pressure operating on the outside. The pump is held together by one nut on the opposite side of the pump to the external air valve. This design allows in-line diaphragm replacement to be accomplished in less than 15 minutes, with a complete stripdown and rebuild possible in less than 20 minutes.

Flotronic Pumps Limited. Ricebridge Works, Brighton Road, Bolney, West Sussex RH17 5NA. UK
 Tel: +44 (0) 1444 881 871 Fax: +44 (0) 1444 881 860
 E-mail: sales@flotronicpumps.co.uk Web: www.flotronicpumps.co.uk

Flotronic is a UK registered trade mark

For authentic Flotronic pump spares go to www.flotronicspares.co.uk



Certificate No. 6597



Literature Minichem Leaflet - 04/2010

*ATEX Gas Group IIC compliant pumps now available



UNIQUE NEW RANGE FROM FLOTTRONIC



The Minichem range PTFE 'ONE-BLOCK' pumps

MINICHEM unique One-Block PTFE pump

Flotronic's existing PTFE pump range enjoys a well-deserved reputation for the safe, efficient and cost-effective transfer of aggressive chemicals at the high-end of the duty range (up to 600 ltr/min).

Now customers can enjoy all the benefits of Flotronic's 'ONE-NUT' design when transferring aggressive chemicals at lower flow rates - up to 100 ltr/min and just as cost-effectively - with the fantastic new Flotronic Minichem pump.

Totally new design

Flotronic have developed a totally new and unique pump.

The Minichem is machined from one solid block of PTFE. Crucially, it is based on our tried and tested unique 'ONE-NUT' design, but has no separate manifolds and so no manifold seals and obvious leak paths.

The Minichem is able to transfer aggressive chemicals and other hazardous materials up to 50 litres and 100 litres per minute through 1/2" and 1" connections respectively. Because it is machined from a solid block of PTFE, there is no need for the stainless steel housing normally associated with Flotronic's higher flow rate Chemflo PTFE pumps.

One of the great benefits of the new pump is that its 'ONE-BLOCK' approach enhances still further the ease of maintenance benefit which Flotronic's 'ONE-NUT' design so effectively pioneered. Minichem maintenance can therefore focus on the 'ONE-NUT' disassembly and on the ball valves only when necessary.



Benefits of the new 'Minichem' include:

- 'ONE-NUT' technology and ease of maintenance for the low-end aggressive chemical duty range
- ability to handle aggressive chemicals and other hazardous materials at temperatures (up to 80°C)
- absence of separate manifolds giving greater pump integrity, fewer parts to go wrong or wear out and ease of maintenance

- ultra safe
- all external parts in polypropylene and stainless steel
- an ATEX approved version where required (FDA approved anti-static).

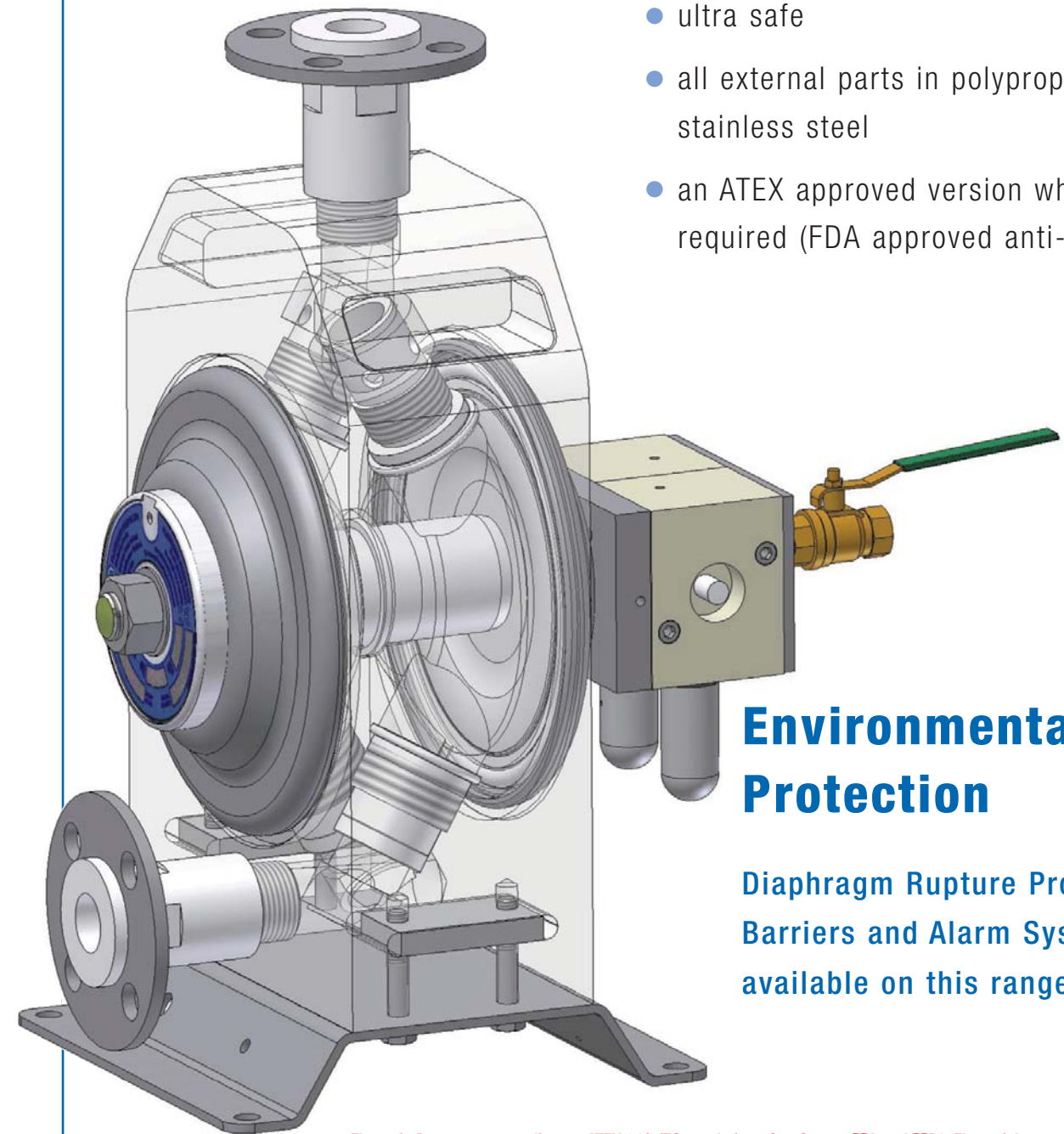

Environmental Protection

Diaphragm Rupture Protection Barriers and Alarm Systems are available on this range of pumps.

Flotronic Pumps are compliant to ATEX 94/9/EC regulations Gas Groups IIA and IIB*. Flotronic's commitment to high quality management of the processes that create and control our products has been recognised in achievement of ISO 9001 accreditation, the internationally recognised standard for the quality management of businesses.

*Gas Group IIC - price available on request.